

VENT-AXIA SCEPTRE PLATE MOUNTED AXIAL FANS DIMENSIONS (mm)

SCEPTRE 250-710

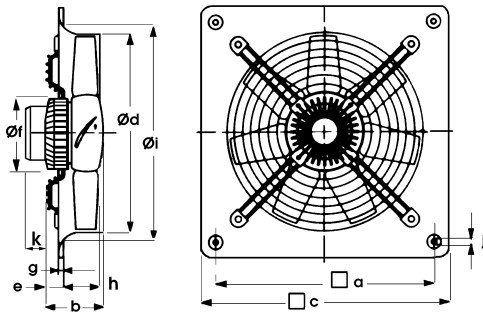

SCEPTRE 800-1000

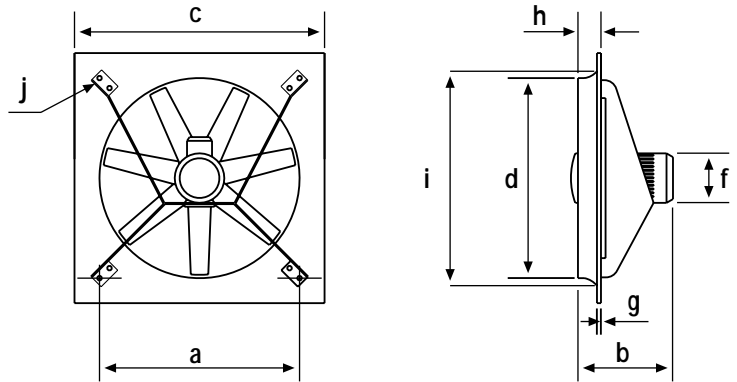

size	a	b	c	Ød	e	Øf	g	h	Øi	Øj	k	kg approx
250	260	122	315	261	59	122	12	53	294	10	65	5
315	330	122	400	320	32	122	12	68	329	10	65	7
355	380	129	450	363	45	129	12	75	371	10	65	8
400	420	129	500	410	40.5	129	12	78	422	10	65	9
450	480	150	560	457	48	150	12	91	476	10	65	13
500	560	150	630	512	44.5	150	12	97	536	10	65	16
560	630	220	710	570	110	218	12	100	596	10	65	22
630	710	220	800	640	110	218	12	103	674	12	65	25
710	800	220	900	710	134	218	16.5	91	733	12	65	27
800	800	380	1000	800	-	203	16	92	926	18	-	52
1000	1000	380	1250	1000	-	203	16	110	1154	18	-	95

ACCESSORIES DIMENSIONS (mm)

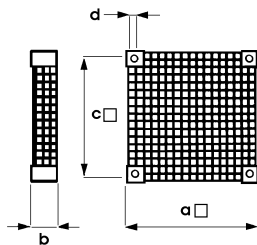

DISCHARGE GUARD
'K' factor loss 0.25

Stock Ref. No.	a	b	c	Ød
105 02 325	397	64	351	8
105 02 375	449	64	403	8
105 02 450	501	64	455	8
105 02 525	553	64	507	8
105 02 630	808	150	735	8

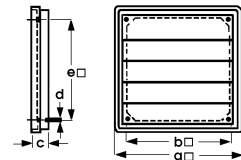

LOUVRE SHUTTER

Stock Ref. No.	a	b	c	d	e
105 01 250	294	265	25	5	230
105 01 315	360	310	27	5	295
105 01 355	411	349	27	5	329
105 01 400	456	409	27	5	382
105 01 450	505	458	27	5	432
105 01 500	560	508	27	5	477
105 01 560	605	565	31	5	533
105 01 630	696	657	31	5	626
LS710	790	-	43	6	722
LS800C	890	-	43	6	820
LS1000C	1137	-	43	6	1068

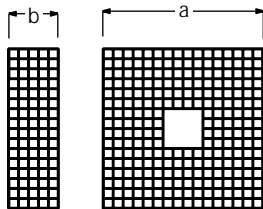

INLET GUARD

Stock Ref. No.	a	b
105 08 1000B	1260	265

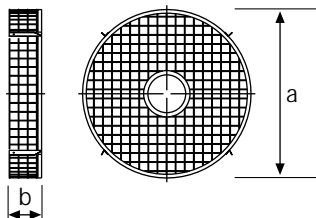

INLET GUARD

Stock Ref. No.	a	b
105 08 800A	1010	140
105 08 1000A	1260	155

